

SeaConnect™ Valve Position Sensor

RMSpumptools Subsea Valve Sensor provides the exact position of the subsea valve. The Subsea Valve Position Sensor can be used on a variety of valve applications including Choke and HIPPS. The 2 wire, 4-20mA current loop output, non-contacting magnetic Subsea Valve Position Sensors are available in various styles and configuration to harness/mate with subsea connectors as a package supply.

Operating Principle

The Subsea Valve Position Sensor measures the direction of the magnetic field generated by external magnets. The system can be divided into two main mechanical components, the magnetic drivehead assembly and the sensor body assembly.

The magnetic drivehead assembly is attached to the output shaft of the valve actuator. When the valve moves, the magnetic drivehead assembly rotates around four magnetic sensors built inside the nose of the sensor body assembly. The angle of the magnetic field relative to the sensor body assembly is determined by measuring two components of the field at right angles to each other.

These magnetic resolutes are processed by the electronics inside the magnetic sensor assembly, resulting in a closed loop signal of between 4mA and 20mA.

Key Performance Features

Ultra Deep Water Capability

Sensors suitable for depths of up to 3,000 metres.

Non-Contacting

No moving parts or dynamic seals to wear.

Solid-State Electronic Components

Ensures superb levels of reliability and accuracy with low drift characteristics.

Extensive Shock and Vibration Tested

M.T. failure analysis calculated at 67 years.

Manufactured to ISO 9001 Standards

Designed, manufactured, assembled and rigorously tested to ISO 9001 approved quality standards.

EMC Tested to EN61326-1: 2013

Electrical equipment for measurement, control and laboratory use – EMC requirements - Part 1: General requirements

CB Tested to IEC 61010-1: 2010

Safety requirements for electrical equipment for measurement, control and laboratory use – Part 1

ACMA DoC for RCM Marking

For use in Australia & New Zealand

Interchangeable in the Field

Each sensor is programmed and calibrated on master rig, then pressure tested as per customer requirements.

Bespoke Solutions

To meet specific customer applications.

Experience

Since their North Sea debut in 1992, over 550 Subsea Valve Position Sensors have been installed to date. The Sensors have been proven using extensive shock and vibration tests.

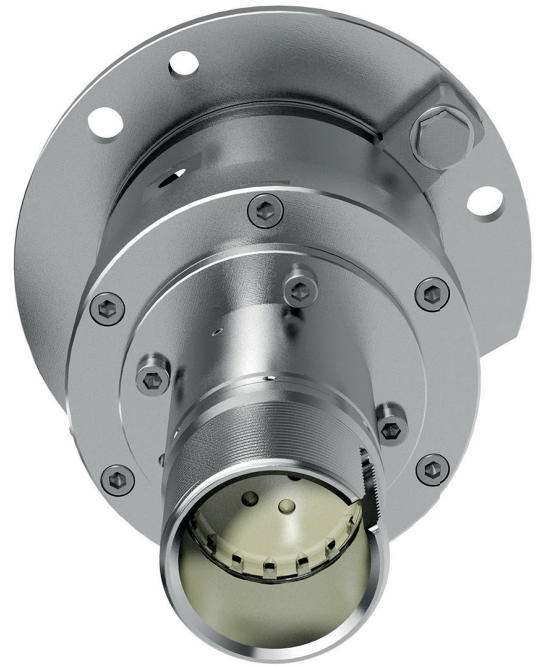

CB CE



SeaConnect™

Valve Position Sensor

Design Specifications (all models)

Angle of Operation:	0° to 360° (to customer specification)
Accuracy:	Better than ± 0.6% (0.4% optional)
Resolution:	Better than ± 0.05%
Input Voltage:	14 to 28 VDC
Output Current:	4 to 20 mA (normal range)
Update Rate:	3Hz
Operating Temperature:	-20°C to 40°C
Max. Operating Depth:	1500 metres standard (3000 metres optional)
Test Pressure:	To Customer Specification

Customer Options

- Standard or Ultra Deep Water
- Single or Dual Output
- Pillar mounted or Flush Fitting design
- Standard or high accuracy (0.6% or 0.4% of full scale deflection)
- Angle of operation programmed to customer specification (up to 360°)
- Clockwise or Counter Clockwise direction of operation
- Fitted with subsea electrical connector of choice
- Dual Output models fitted with one or two connectors
- Pressure testing to suit customer specifications
- Vibration and Thermal testing to suit customers requirements

PM1 Pillar Mounted Single Output

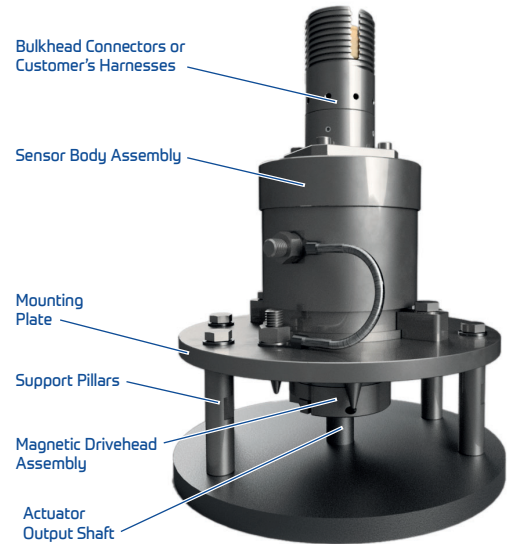

FF1 Flush Fitting Single Output

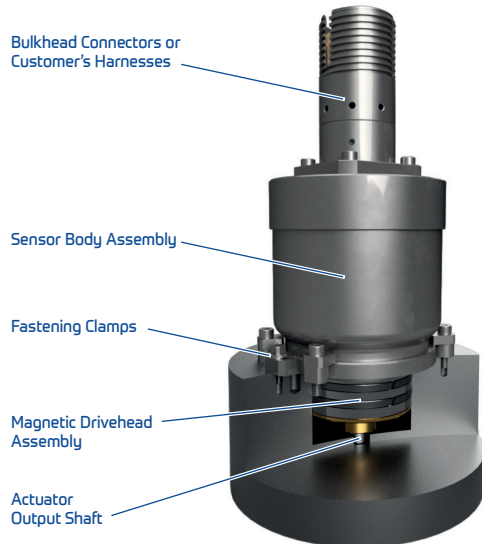

PM2 Pillar Mounted Dual Output

